

AS950 ALL-WEATHER REFRIGERATED SAMPLER



Applications

- Wastewater
- Collection systems
- Industrial pretreatment
- Environmental monitoring
- Stormwater

Sampling has never been this easy.

Hach's AS950 sampler controller makes programming, data transfer and operation more intuitive and error-free.

Easiest and most intuitive operation

The large full colour display and intuitive programming give you access to all your programmable criteria on a single screen - eliminating scrolling through menus and supporting error-free operation.

Most convenient data transfer and programming available

The AS950 is the only sampler that utilises a USB drive to upload and download data and copy programs from one sampler to another.

Confidence in your sampling process

The program status screen instantly communicates alarms, missed samples and program progress for quick and easy troubleshooting.

Resists corrosion

The All-Weather Refrigerated (AWR) sampler base is designed to endure humid and highly corrosive environments, minimising damage caused by corrosive gases, rodents, and standing water to guarantee environmental integrity.

Accurate and consistent sample preservations

The custom-designed air-sensing thermostat controls temperature in accordance with USEPA and international guidelines, preserving samples regardless of outside temperatures and conditions.



Be Right™

Technical Data*

AS950 All-Weather Refrigerated Sampler (AWRS)

Housing material	IP24, low-density Polyethylene with UV inhibitor (Sampler)
Refrigeration components and plumbing	Corrosion protected with conformal all exposed copper tubing is insulated to avoid sweating and condensation
Cooling system	Top mounted compressor and fan-forced air cooled condenser; 11/5 HP 115 VAC: 115 °C thermal overload protector, 7.1 locked rotor amps; 230 VAC: 120 °C thermal overload protector, 7.6 A peak start current; 3-sided wraparound plate type evaporator; Rigid foam insulation: 7.6 cm sides, 12.7 cm top, 15.2 cm bottom; Lockable lid to prevent tampering with programming; Recovery Time: Sampler temperature recovers to 4 °C within 5 minutes after door has been held open for one minute in 24 °C ambient environment while in an active cooling cycle; Pull Down Time: from 24 °C to 4 °C , 20 minutes; Temperature Control: 4 °C (±0.8 °C)
Sample container	SINGLE BOTTLE: (1) 10 L Glass or Polyethylene, or 21 L Polyethylene MULTIPLE BOTTLES: (2) 10 L Polyethylene or Glass, (4) 10 L Polyethylene or Glass, (8) 2.3 L Polyethylene or 1.9 L Glass, (12) 2 L Polyethylene, (24) 1 L Polyethylene or 350 mL Glass
Pollution degree	2
Temperature	Operating: AWRS: 0 - 50 °C AWRS with optional controller compartment heater: -40 - 50 °C AWRS with controller compartment heater and AC battery back up: -15 - 40 °C Storage: -30 - 60 °C
Power requirements (Voltage)	115/230 V AC
Power requirements (Hz)	50/60 Hz
Dimensions	76 cm x 81 cm x 130 cm
Weight	86 kg
Certifications	CE, UL, CSA

AS950 Controller

Housing material	PC/ABS blend, NEMA 4X, 6, IP68, corrosion and ice resistant (Controller)
Display	1/4 VGA, Colour; self-prompting/menu-driven program
User interface	Membrane switch keypad with 2 multiple function soft keys
Languages user interface	en, fr, es, it, de, pt, zh, tr, hu, cz, pl, ro, hr, el, sl, sk, fi, ru, ja, ko
Lock function	Access code protection prevents tampering
Memory	Sample history: 4000 records; Data log: 325,000 records; Event log: 2000 records
Communication capabilities	USB and optional RS485 (Modbus)
Inputs	One 0/4-20 mA input for flow pacing
Certifications	CE, UL

**Subject to change without notice.*

Technical Data*

Sampling Features

Programs

Dual Programs: Up to 2 sample programs can be run sequentially, in parallel, or according to day of week scheduling; enabling a single sampler to function like multiple samplers

Sampling mode

Pacing: Time weighted, Flow weighted, Time table, Flow table, Event

Distribution: Single bottle composite, multi-bottle composite, multi-bottle discrete, bottles per sample, samples per bottle or a combination of bottles per sample and samples per bottle

Operating mode

Continuous or non-continuous

Status messages

Communicates what program is running, if there are any missed samples, when the next sample will be taken, how many samples remain, number of logged channels, time of last measurement, memory available, number of active channels, if alarms were triggered, when alarms were triggered, active sensors and cabinet temperature

Alarm

Configurable alarms that show on status screen and are recorded in diagnostics alarm logs. Alarms can be set for system diagnostics and logging such as program end, sample complete, missed samples and full bottle. Channel alarms are setpoint alarms for the recorded measurements (channels), such as pH, level and power supply voltage.

Manual sampling

Initiates a sample collection independent of program in progress

Automatic shutdown

Multiple Bottle Mode: After complete revolution of distributor arm (unless Continuous Mode is selected)

Composite Mode: After preset number of samples have been delivered to composite container, from 1 to 999 samples, or upon full container.

Sample volume

Programmable in 10 mL increments from 10 to 10,000 mL

Sample interval

Selectable in single increments from 1 to 9999 flow pulses or 1 to 9999 minutes in one minute increments

Sample trigger

When equipped with flow sensor or pH/temperature sensor or peripheral monitoring options, sampling can be triggered upon an upset condition when field selectable limits are exceeded

Data logging

SAMPLE HISTORY - Stores up to 4000 entries for sample time stamp, bottle number and sample status (success, bottle full, rinse error, user abort, distributor error, pump fault, purge fail, sample timeout, power fail and low main battery).

MEASUREMENTS - Stores up to 325,000 entries for selected measurement channels in accordance with the selected logging interval.

EVENTS - Ability to store up to 2000 entries in Sample History logging. Records Power On, Power Fail, Firmware Updated, Pump Fault, Distributor Arm Error, Low Memory Battery, Low Main Battery, User On, User Off, Program Started, Program Resumed, Program Halted, Program Completed, Grab Sample, Tube Change Required, Sensor Communication Errors, Cooling Failed, Heating Failed, Thermal Error Corrected.

Diagnostics

View event and alarm logs as well as maintenance diagnostics

**Subject to change without notice.*

Technical Data*

Sample Pump and Strainer

Sample pump

High-speed peristaltic, dual roller, with 0.95 ID x 1.6 OD cm (3/8" ID x 5/8" OD) pump tube;

Pump body IP37, Polycarbonate cover

Vertical lift

8.5 m using 8.8 m maximum of 3/8" Vinyl intake tube at sea level at 20 to 25 °C

Tubing

Pump tubing: 9.5 mm ID x 15.9 mm OD Silicone

Intake tubing: 1.0 - 4.75 m minimum length, 1/4" or 3/8" ID Vinyl or 3/8" ID PTFE-lined Polyethylene with protective outer cover (black or clear)

Sample volume repeatability

Typical: $\pm 5\%$ of 200 mL sample volume with: 4.6 m vertical lift, 4.9 m of 3/8" Vinyl intake tube, single bottle, full bottle shut-off at room temperature and 1524 m elevation

Sample volume accuracy

Typical: $\pm 5\%$ of 200 mL sample volume with: 4.6 m vertical lift, 4.9 m of 3/8" Vinyl intake tube, single bottle, full bottle shut-off at room temperature and 1524 m elevation

Sample transport velocity

0.9 m/s with 4.6 m vertical lift, 4.9 m of 3/8" Vinyl intake tubing, 21 °C and 1524 m elevation

Pump flow rate

4.8 L/min at 1 m vertical lift with 3/8" intake tube typical

Internal clock

± 1 second per day at 25 °C

Intake

Strainers: Choice of PTFE and 316 stainless steel construction, or all 316 stainless steel in standard size, high velocity, and low profile for shallow depth applications

Purge: Air purged automatically before and after each sample; duration automatically compensates for varying intake line lengths

Rinse: Intake line automatically rinsed with source liquid prior to each sample, from 1 to 3 rinses

Retries or Fault: Sample collection cycle automatically repeated from 1 to 3 times if sample not obtained on initial attempt

**Subject to change without notice.*

Dimensions

The refrigeration compartment door of the AS950 All-Weather Refrigerated Sampler is lockable (two keys are provided). The lid is also lockable for added security.

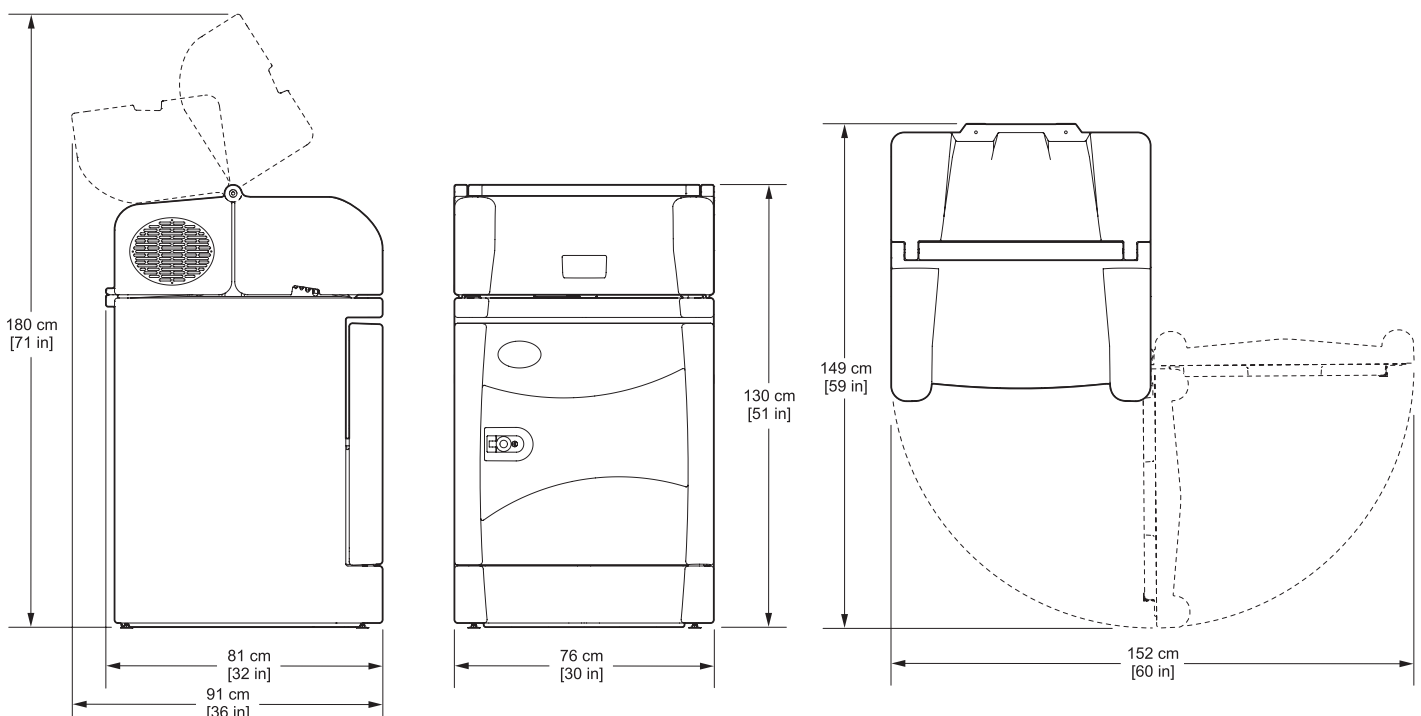

Order Information

ASA.XXXXXXXXXX AS950 AWRS Automatic Sampler
All-Weather Refrigerated Sampler with AS950 Controller, available in various configurations and with several factory installed options. Please contact Hach for more information.

Bottle Options and Accessories

1918 10 L Polyethylene bottle, with cap
6494 20 L Polyethylene bottle, with cap
2318 Set of (2) 10 L Glass bottles, with PTFE-lined caps
2316 Set of (2) 10 L Polyethylene bottles, with caps
2317 Set of (4) 10 L Glass bottles, with PTFE-lined caps
2315 Set of (4) 10 L Polyethylene bottles, with caps
737 Set of (24) 1 L Polyethylene bottles, with caps
1511 Bottle tray for 24 and 8 bottle sets
1322 Retainer for (24) 1 L polyethylene bottles and (8) bottle sets
3527 Extension tube for composite sampling
8838 Composite tube support for all composite containers
8847 Full container shut off for Refrigerated and All Weather Samplers

Distributors

8841 Distributor w/ arm for 12 and 24 bottle configurations
8842 Distributor w/ arm for 8 bottle configuration
8843 Distributor w/ arm for 2 and 4 bottle configurations

Tubing and Strainers

920 7 m Vinyl intake tubing, 3/8" ID
922 7 m PTFE-lined Polyethylene tubing, 3/8" ID (requires Connection Kit 2186)
926 Strainer, PTFE/Stainless Steel
2070 Strainer, 316 Stainless Steel
2071 Strainer, for shallow depth applications, 316 Stainless Steel
2186 Connector Kit, for PTFE-lined Polyethylene tubing
4652 Strainer, high velocity and shallow depth
4600-15 Pump tubing, 4.5 m
4600-50 Pump tubing, 15 m
8888 Pump tube insert

Factory Installed Options

TWO SENSOR PORTS

Accepts Hach digital Differential pH, Hach digital AV9000 analyser with submerged area velocity flow and/or Hach digital US9000 ultrasonic level sensors

RAIN/RS485 PORT

Accepts Hach Rain Gauge (not included) or can be used as RS485 communications

NON-CONTACT LIQUID DETECT

Sample volume accuracy for applications that require complete tubing replacement

Please contact your local Hach representative for details.

Inputs/Outputs

9494500 IO9001 Module (connects through auxiliary port), includes 1 relay (high voltage)
9494600 IO9004 Module (connects through auxiliary port), includes multiple 0/4-20 mA outputs and inputs

Accessories

6613100 All-Weather Sampler cabinet anchor mounting kit
9504700EU USB cable, A to A (EU)